

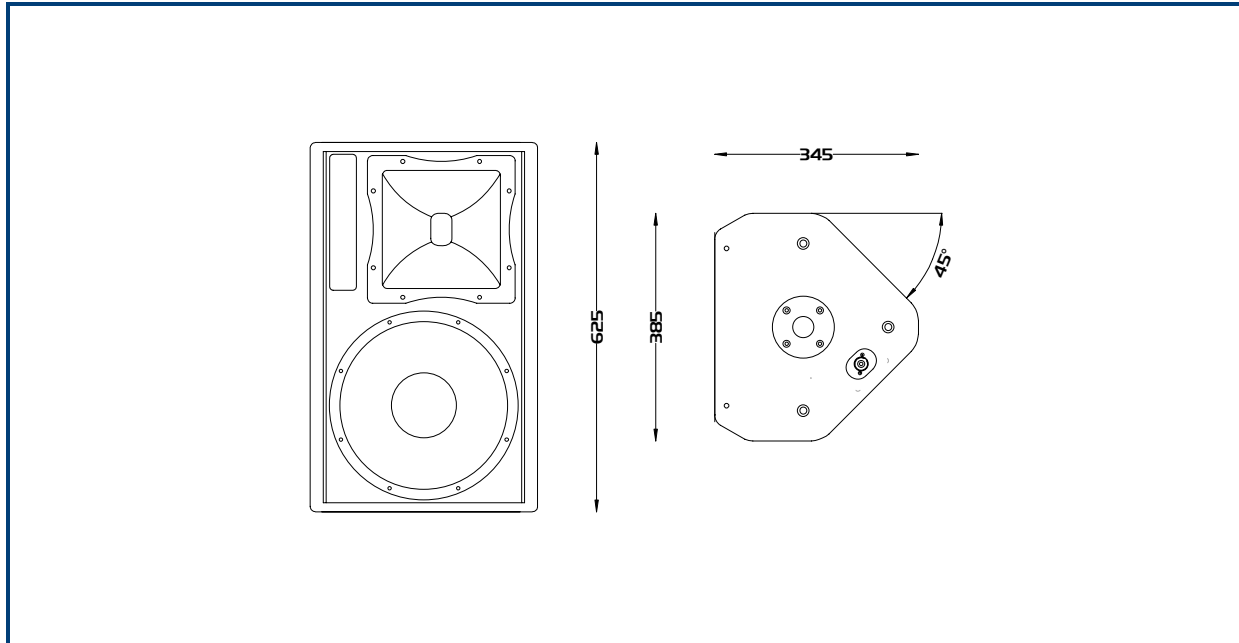

The ML12 is a compact, high power, multipurpose, fullrange loudspeaker enclosure. The cabinet combines a 12" mid/bass cone with a 1" compression driver on a 90° x 40° horn flare. The horn flare rotates to aid use in both landscape and portrait applications. The cabinet can be used Fullrange or combined with the B1 bass enclosure to form an integrated system. The ML12 contains an internal passive crossover network, but for optimum sonic performance should be used with the DP2140 system controller. The Logic Systems DP2140 controller contains presets for using the cabinet freestanding or as a system. The multipurpose nature of the cabinet makes it suitable for a variety of applications including FOH, monitoring, stage fills and delays. Target markets for the product include church, live sound, theatre and A/V.



Frequency Response:	• 55Hz – 20kHz
Components:	• Bass/mid: 12" cone driver • HF: 1" exit compression driver
Power handling:	• 400W
Sensitivity (1):	• 98dB
Directivity:	• 90° x 40° above 1.5kHz
Impedance:	• 8 Ohm
Construction:	• 15mm Birch plywood
Finish:	• Water based textured black paint
Connections:	• 4 x Neutrik NL4 connectors • 1+/1- Input 2+/2- N/C.
Dimensions:	• 385mm (W) x 625mm (H) x 345mm (D)
Packaged Dimensions:	• 510mm (W) x 780mm (H) x 465mm (D)
Weight:	• 27 Kg

Cabinet	Handles	Tophat	M20 plate	Castors	Bracket Pt.	Inserts/Fly Points
ML 12	2 off	Yes	No	No	Top/Side	6 off

Note: (1) Sensitivity measured at 1 metre with 2.83V, using band limited pink noise.